ADA Checklist

Approach and Entrances



Institute for Human Centered Design
www.HumanCenteredDesign.org
2014



ADA National Network
Questions on the ADA 800-949-4232
voice/tty
www.ADAchecklist.org

This checklist was produced by the New England ADA Center, a project of the Institute for Human Centered Design and a member of the ADA National Network. This checklist was developed under a grant from the Department of Education, NIDRR grant number H133A060092-09A.

This is an edited version of the checklist. For the full set of checklists, including the checklists for recreation facilities visit www.ADAchecklist.org.

Local Government Name:

Project Name:

Approach & Entrance

1.1 Is there at least one route from site arrival points (parking, passenger loading zones, public sidewalks and public transportation stops) that does not require the use of stairs?
[See 2010 ADA Standards for Accessible Design – 206.2.1]

Yes No

1.2 If parking is provided for the public, are an adequate number of accessible spaces provided?
[208.2]

Yes No

Total Spaces	Accessible Spaces
1 - 25	1
26 - 50	2
51 - 75	3
76 - 100	4
100+ see 2010 Standards 208.2	

1.3 Of the accessible spaces, is at least one a van accessible space?*

Yes No

*For every 6 or fraction of 6 parking spaces required by the table above, at least 1 should be a van accessible space.

1.4 Are accessible spaces at least 8 feet wide with an access aisle at least 5 feet wide?
[502.2, 502.3]

Yes No

Note: Two spaces may share an access aisle. Check state/local requirements; some specify that each space have its own aisle.

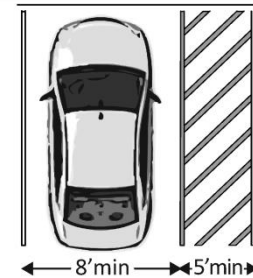





1.5 Is the van accessible space:

At least 11 feet wide with an access aisle at least 5 feet wide?
Or
At least 8 feet wide with an access aisle at least 8 feet wide?
[502.2]

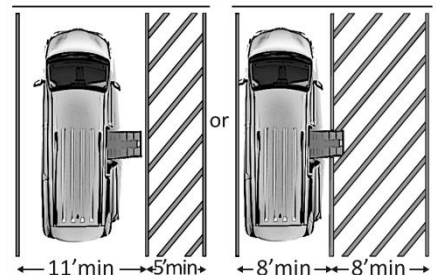
Yes No

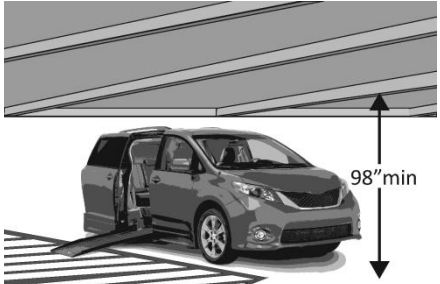
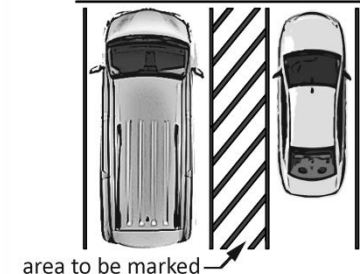
Yes No

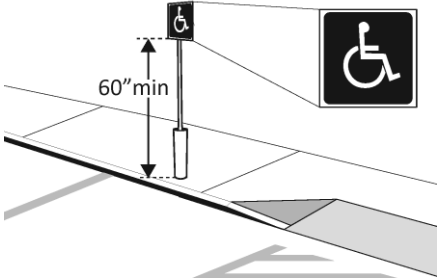

<p>1.6 Is at least 98 inches of vertical clearance provided for the van accessible space? [502.5]</p>	<p><input type="checkbox"/> Yes <input type="checkbox"/> No</p>	
<p>1.7 Are the access aisles marked so as to discourage parking in them? [502.3.3]</p> <p>Note: The marking method and color may be addressed by state/local requirements.</p>	<p><input type="checkbox"/> Yes <input type="checkbox"/> No</p>	
<p>1.8 Is the slope of the accessible parking spaces and access aisles no steeper than 1:48 in all directions? [502.4]</p>	<p><input type="checkbox"/> Yes <input type="checkbox"/> No</p>	
<p>1.9 Do the access aisles adjoin an accessible route? [502.3]</p>	<p><input type="checkbox"/> Yes <input type="checkbox"/> No</p>	
<p>1.10 Are accessible spaces identified with a sign that includes the International Symbol of Accessibility?</p> <p>Is the bottom of the sign at least 60 inches above the ground? [502.6]</p> <p>Note: The International Symbol of Accessibility is not required on the ground.</p>	<p><input type="checkbox"/> Yes <input type="checkbox"/> No</p> <p><input type="checkbox"/> Yes <input type="checkbox"/> No</p>	
<p>1.11 Are there signs reading "van accessible" at van accessible spaces? [502.6]</p>	<p><input type="checkbox"/> Yes <input type="checkbox"/> No</p>	

ADA Checklist **Approach and Entrance**

1.12 Of the total parking spaces, are the accessible spaces located on the closest accessible route to the accessible entrance(s)?
[208.3.1]

Yes No

Note: If parking serves multiple entrances, accessible parking should be dispersed.

1.13 Is the route stable, firm and slip-resistant?
[302.1]

Yes No

1.14 Is the route at least 36 inches wide?
[403.5.1]

Yes No

Note: The accessible route can narrow to 32 inches min. for a max. of 24 inches. These narrower portions of the route must be at least 48 inches from each other.

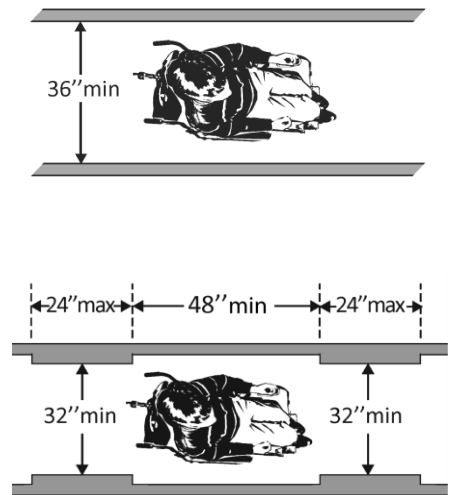

1.15 If the route is greater than 200 feet in length and less than 60 inches wide, is there a passing space no less than 60 x 60 inches?
[403.5.3]

Yes No

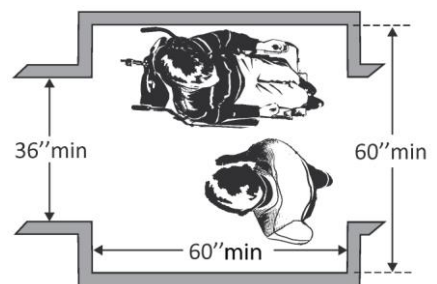

1.16 If there are grates or openings on the route, are the openings no larger than 1/2 inches?

Yes No

Is the long dimension perpendicular to the dominant direction of travel?
[302.3]

Yes No

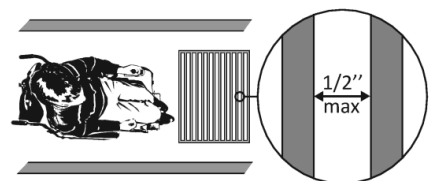

ADA Checklist **Approach and Entrance**

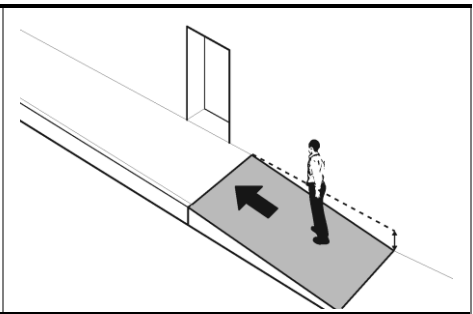
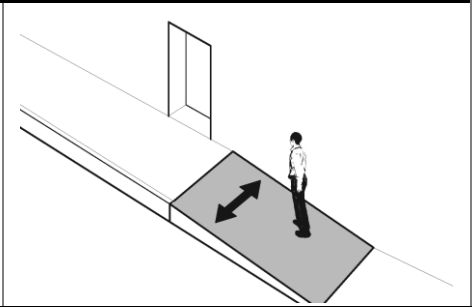
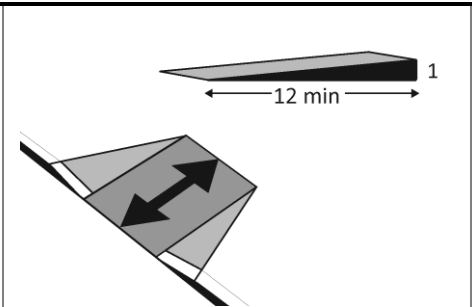
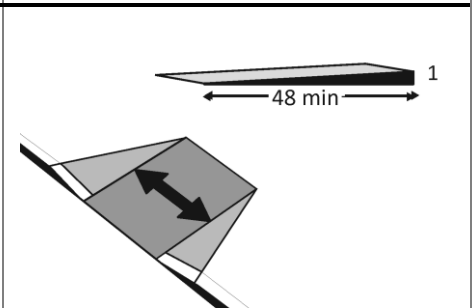
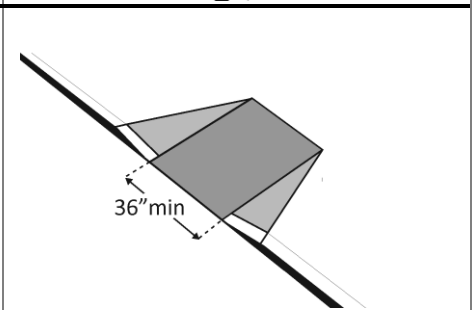
<p>1.17 Is the running slope no steeper than 1:20, i.e. for every inch of height change there are at least 20 inches of route run? [403.3]</p> <p>Note: If the running slope is steeper than 1:20, treat as a ramp and add features such as edge protection and handrails.</p>	<p><input type="checkbox"/> Yes <input type="checkbox"/> No</p>	
<p>1.18 Is the cross slope no steeper than 1:48? [403.3]</p>	<p><input type="checkbox"/> Yes <input type="checkbox"/> No</p>	
<p>1.20 Is the running slope of the curb ramp no steeper than 1:12, i.e. for every inch of height change there are at least 12 inches of curb ramp run? [406.1, 405.2]</p>	<p><input type="checkbox"/> Yes <input type="checkbox"/> No</p>	
<p>1.21 Is the cross slope of the curb ramp, excluding flares, no steeper than 1:48? [406.1, 405.3]</p>	<p><input type="checkbox"/> Yes <input type="checkbox"/> No</p>	
<p>1.22 Is the curb ramp, excluding flares, at least 36 inches wide? [406.1, 405.5]</p>	<p><input type="checkbox"/> Yes <input type="checkbox"/> No</p>	

ADA Checklist **Approach and Entrance**

1.23 At the top of the curb ramp is there a level landing (slope no steeper than 1:48 in all directions) that is at least 36 inches long and at least as wide as the curb ramp?
[406.4]

If there are curb ramp flares, are the slopes of the flares no steeper than 1:10, i.e. for every inch of height change there are at least 10 inches of flare run?
[406.3]

Yes No

Yes No

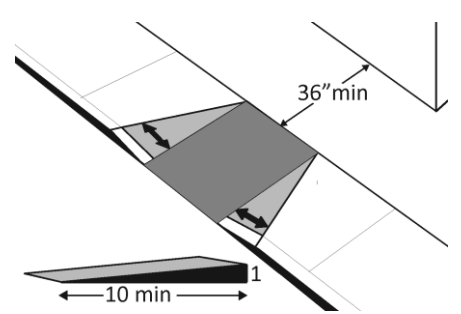

1.24 If the landing at the top is less than 36 inches long, are there curb ramp flares?

Are the slopes of the flares no greater than 1:12, i.e. for every inch of height change there are at least 12 inches of flare run?
[406.4]

Yes No

Yes No

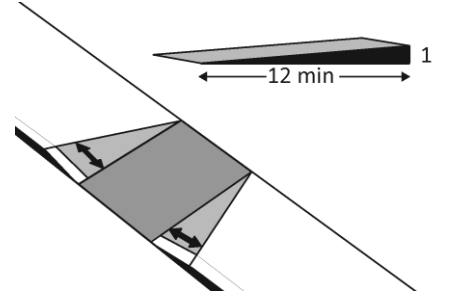

Ramps If any portion of the accessible route is steeper than 1:20, it should be treated as a ramp.

1.25 If there is a ramp is it at least 36 inches wide?
[405.5]

Note: If there are handrails, measure between the handrails.

Yes No

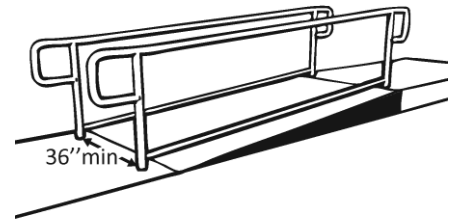

1.26 Is the surface stable, firm and slip resistant?
[405.4]

Yes No

1.27 For each section of the ramp, is the running slope no greater than 1:12, i.e. for every inch of height change there are at least 12 inches of ramp run?
[405.2]

Note: Rises no greater than 3 inches with a slope no steeper than 1:8 and rises no greater than 6 inches with a slope no steeper than 1:10 are permitted when such slopes are necessary due to space limitations.

Yes No

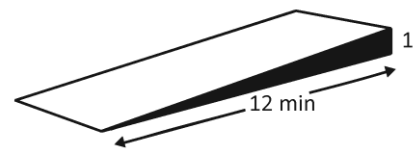

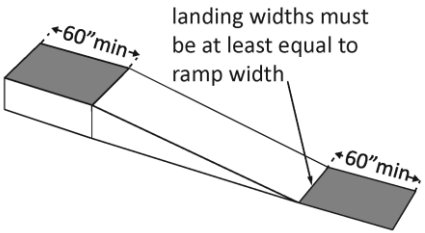
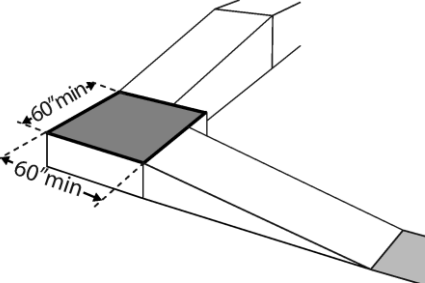
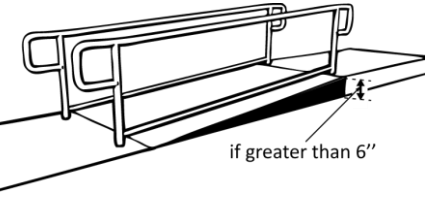
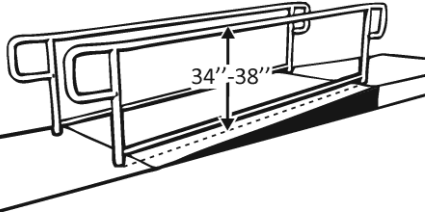
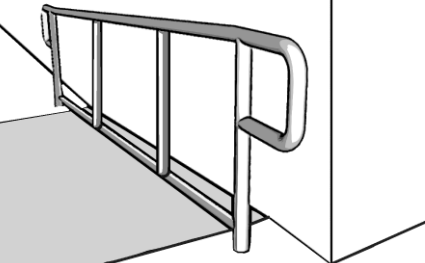
<p>1.28 Is there a level landing that is at least 60 inches long and at least as wide as the ramp:</p> <p>At the top of the ramp?</p> <p>At the bottom of the ramp? [405.7.2, 405.7.3]</p>	<p><input type="checkbox"/> Yes <input type="checkbox"/> No</p> <p><input type="checkbox"/> Yes <input type="checkbox"/> No</p>	
<p>1.29 Is there a level landing where the ramp changes direction that is at least 60 x 60 inches? [405.7.4]</p>	<p><input type="checkbox"/> Yes <input type="checkbox"/> No</p>	
<p>1.30 If the ramp has a rise higher than 6 inches, are there handrails on both sides? [405.8]</p> <p>Note: Curb ramps are not required to have handrails.</p>	<p><input type="checkbox"/> Yes <input type="checkbox"/> No</p>	
<p>1.31 Is the top of the handrail gripping surface no less than 34 inches and no greater than 38 inches above the ramp surface? [505.4]</p>	<p><input type="checkbox"/> Yes <input type="checkbox"/> No</p>	
<p>1.32 Is the handrail gripping surface continuous and not obstructed along the top or sides? [505.3]</p> <p>If there are obstructions, is the bottom of the gripping surface obstructed no greater than 20%? [505.6]</p>	<p><input type="checkbox"/> Yes <input type="checkbox"/> No</p> <p><input type="checkbox"/> Yes <input type="checkbox"/> No</p>	

ADA Checklist **Approach and Entrance**

1.33 If the handrail gripping surface is circular, is it no less than 1 ¼ inches and no greater than 2 inches in diameter?
[505.7.1]

Yes No
Measurement:

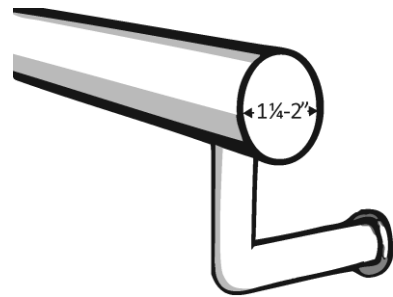

1.34 If the handrail gripping surface is non-circular:

Is the perimeter no less than 4 inches and no greater than 6 ¼ inches?

Is the cross section no greater than 2 ¼ inches?
[505.7.2]

Yes No

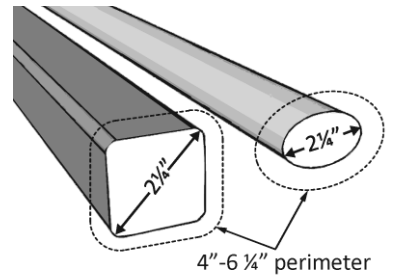

1.35 Does the handrail:

Extend at least 12 inches horizontally beyond the top and bottom of the ramp?

Return to a wall, guard, or landing surface?
[505.10.1]

Note: If a 12 inch extension would be a hazard (in circulation path) it is not required.

Yes No

 Yes No

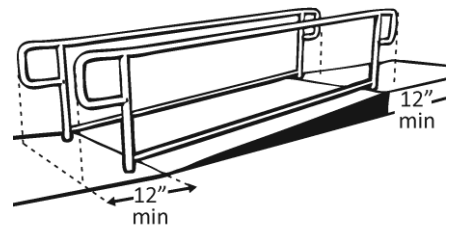

1.36 To prevent wheelchair casters and crutch tips from falling off:

Does the surface of the ramp extend at least 12 inches beyond the inside face of the handrail?
Or
Is there a curb or barrier that prevents the passage of a 4-inch diameter sphere?
[405.9.1, 405.9.2]

Yes No

 Yes No

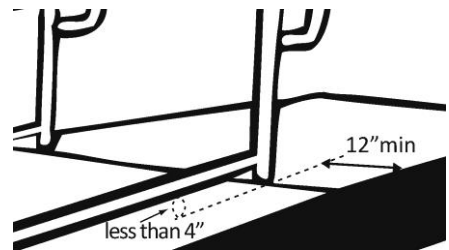

1.37 Is the main entrance accessible?

Yes No

1.38 If the main entrance is not accessible, is there an alternative accessible entrance?

Yes No

Can the alternative accessible entrance be used independently and during the same hours as the main entrance?

Yes No

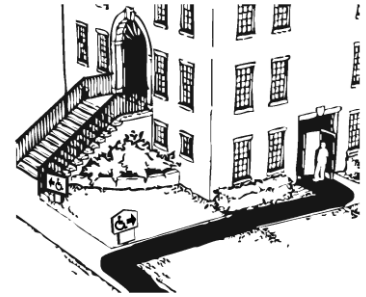

1.39 Do all inaccessible entrances have signs indicating the location of the nearest accessible entrance?
[216.6]

Yes No



1.40 If not all entrances are accessible, is there a sign at the accessible entrance with the International Symbol of Accessibility?
[216.6]

Yes No



1.41 Is the clear opening width of the accessible entrance door at least 32 inches, between the face of the door and the stop, when the door is open 90 degrees?
[404.2.3]

Yes No

Measurement:

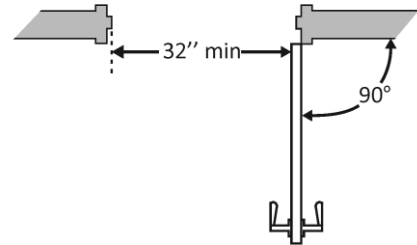

1.42 If there is a front approach to the pull side of the door, is there at least 18 inches of maneuvering clearance beyond the latch side plus at least 60 inches clear depth?

Yes No

Measurement:

Note: See 2010 Standards 404.2.4 for maneuvering clearance requirements on the push side of the door and side approaches to the pull side of the door

On both sides of the door, is the ground or floor surface of the maneuvering clearance level (no steeper than 1:48)?
[404.2.4]

Yes No

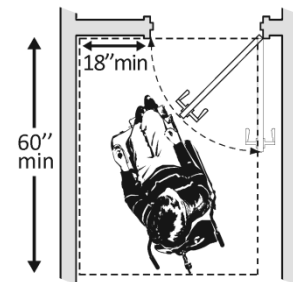

1.43 If the threshold is vertical is it no more than ¼ inch high?
 Or
 No more than ½ inch high with the top ¼ inch beveled no steeper than 1:2, if the threshold was installed on or after the 1991 ADA Standards went into effect (1/26/93)?
 Or
 No more than ¾ inch high with the top ½ inch beveled no steeper than 1:2, if the threshold was installed before the 1991 ADA Standards went into effect (1/26/93)?
 [404.2.5, 303.2]

Note: The first ¼ inch of the ½ or ¾ inch threshold may be vertical; the rest must be beveled.

Yes No

Yes No

Yes No

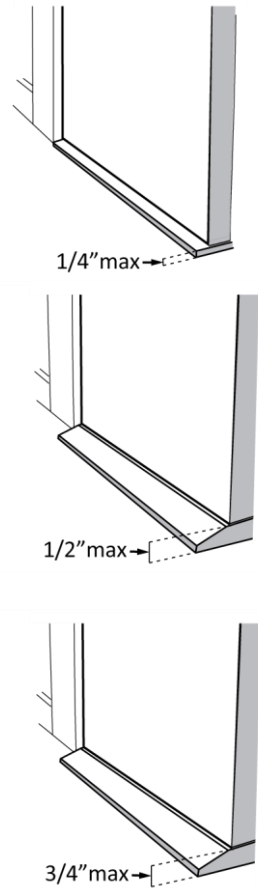

1.44 Is the door equipped with hardware that is operable with one hand and does not require tight grasping, pinching or twisting of the wrist?
 Door handle?
 Lock (if provided)?
 [404.2.7]

Yes No

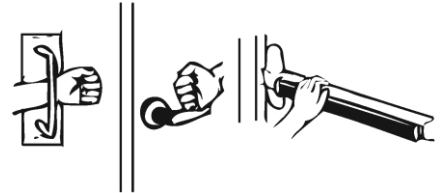

1.45 Are the operable parts of the door hardware no less than 34 inches and no greater than 48 inches above the floor or ground surface?
 [404.2.7]

Yes No

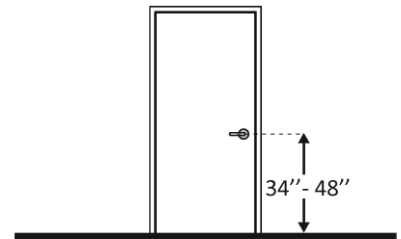

1.46 If the door has a closer, does it take at least 5 seconds to close from an open position of 90 degrees to a position of 12 degrees from the latch?
[404.2.8]

Yes No

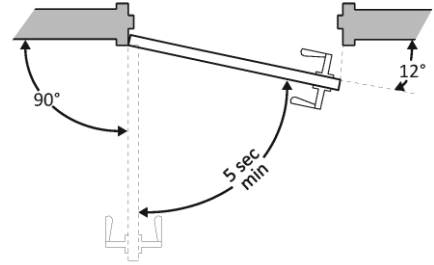

1.47 If there are two doors in a series, e.g. vestibule, is the distance between the doors at least 48 inches plus the width of the doors when swinging into the space?
[404.2.6]

Yes No

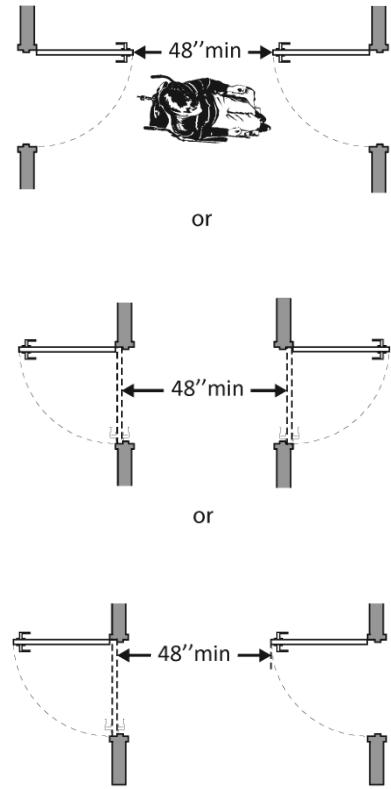

1.48 If provided at the building entrance, are carpets or mats no higher than 1/2 inch thick?
[302.2]

Yes No



1.49 Are edges of carpets or mats securely attached to minimize tripping hazards?
[302.2]

Yes No